

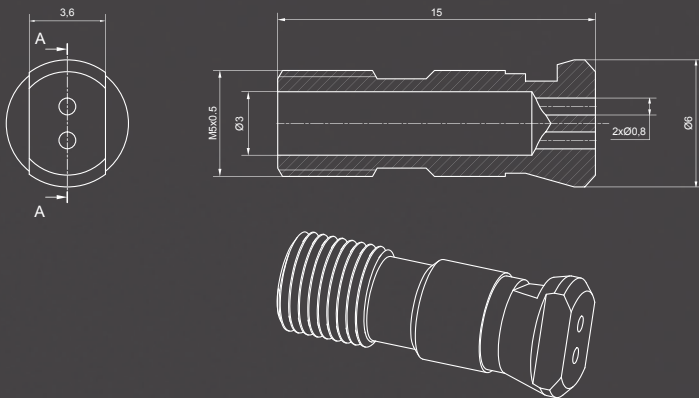

escomatic **NM 6 Flexi**

3,6 PCS/MIN. (303)



THE NEW GENERATION

escomatic NM 6 Flexi

MORE FLEXIBLE, MORE VERSATILE, FASTER



MATERIAL FEED

The material is supplied into the machine from coil. A coil, depending on the type of material, usually has 30 to 60 kg and is unrolled from a reel independent of the machine. The material is pulled across the machine by the material feed system. The machine could be equipped with a bar loader replacing the straightening unit as well as the reel and its support.

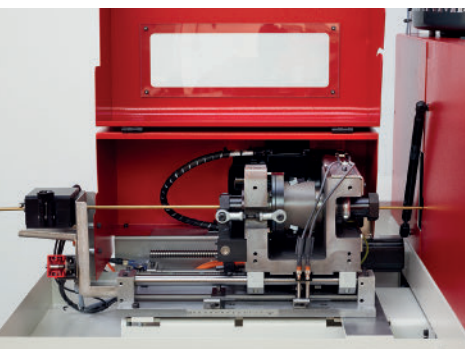

MATERIAL STRAIGHTENING

The material is fed into the machine from coil which becomes «bar stock» after the rotating straightening process. In the process the material is straightened during the recoil of the rotor of the straightening unit. It produces a bar with a straightness quality equivalent to standard bar stock. Thanks to the electric drive and the programming from the console, the quality of straightening is optimized. Improved speed control and a better managed displacement provide a very fine precision of straightening.

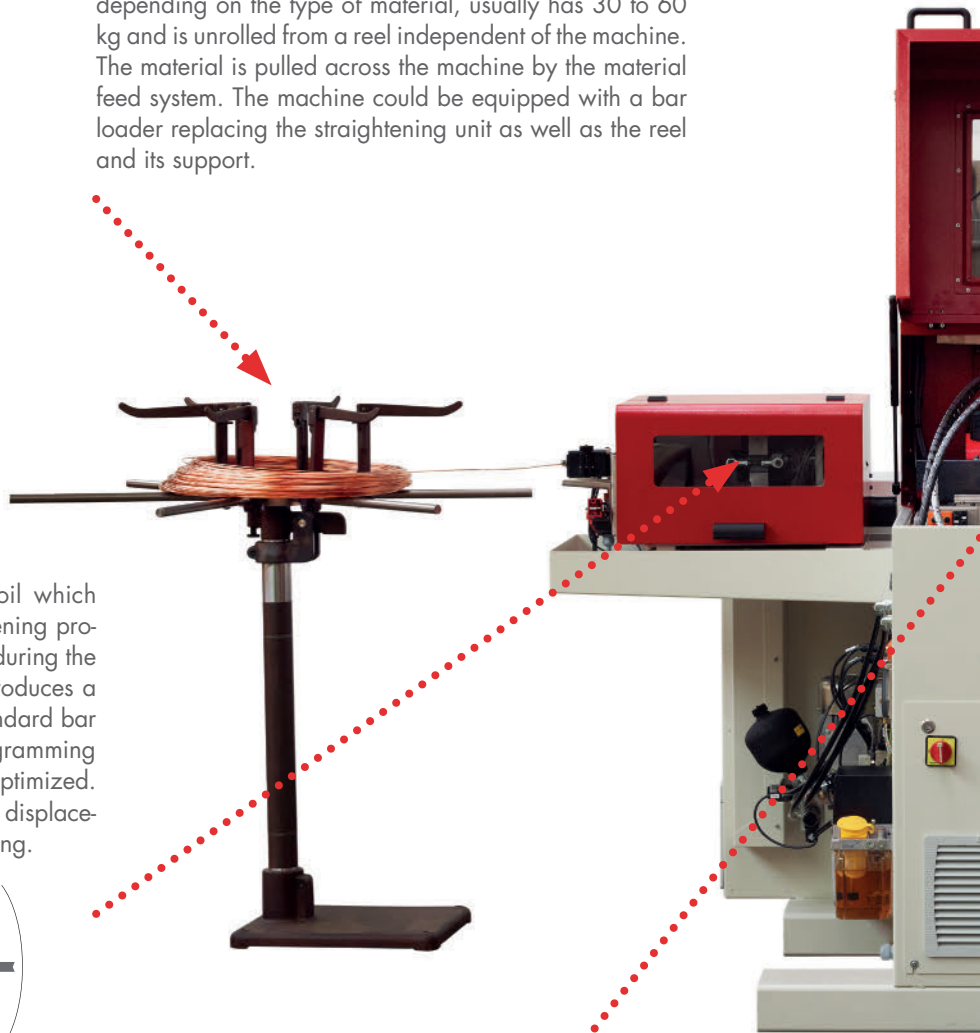
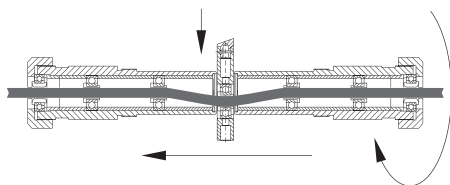

MATERIAL FEEDING

The material is fed and moved in the machine by the CNC controlled Z1-axis and the attached feed system.

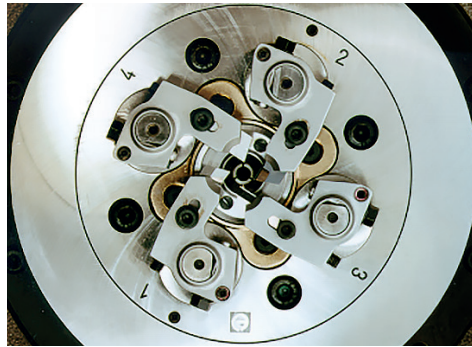

TURNING

The material is fed through a guide bush into the rotating tool head. The turning and cutting is based on the unique escomatic principle in which four turning tools are rotating around the workpiece with up to 10'000 RPM (or 12'000 RPM optional). The cutting tools are either escomatic tools or inserts from other suppliers.

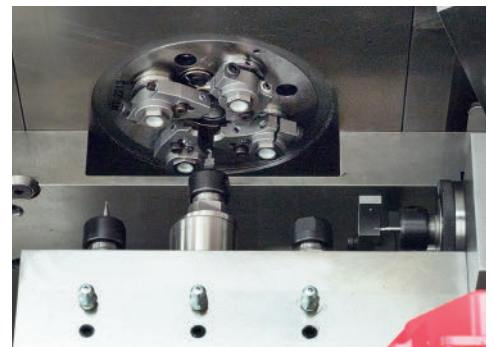
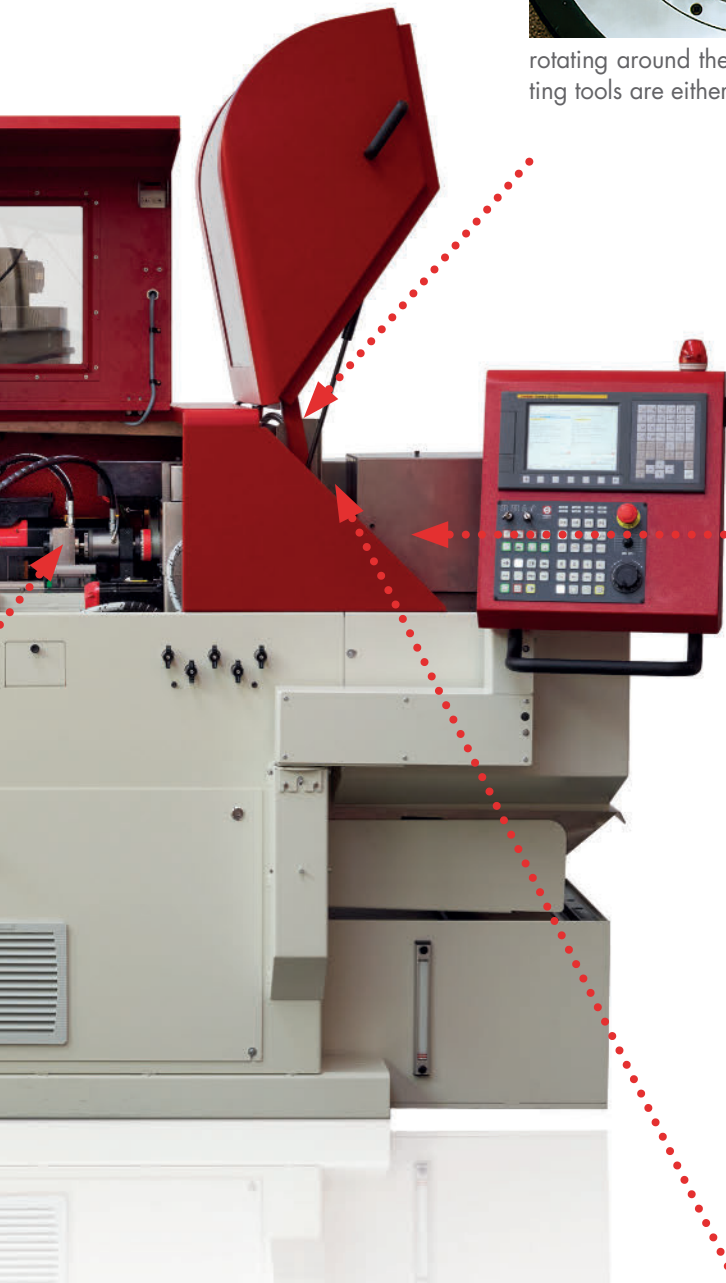

FRONT MACHINING UNIT

The front machining unit (DUF) is positioned on a cross table controlled by two axes. The front machining is therefore totally independent of the back machining unit which provides them with freedom of movement. Equipped with 3 axial spindles, the front machining unit can perform drilling as well as internal and external threading. A fourth transversal spindle (optional) allows side holes or millings.



COUNTER COLLET & BACK MACHINING UNIT

Positioned on a table with three axes, the counter spindle can work in horizontal and vertical planes, thus allowing the use of many tools and facilitating movements. The counter spindle is equipped with a C axis. Used in spindle mode, the maximal rotating speed is 10'000 RPM. Thanks to the flexibility of the Y axis, up to six working positions (4 axial and 2 vertical) can be utilized. In addition to the spindles, it is also possible to install up to 4 cutting tool holders.

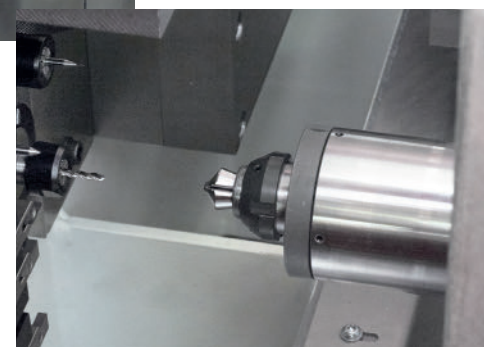

escomatic NM 6 Flexi

MORE FLEXIBLE, MORE VERSATILE, FASTER

The escomatic principle

Unlike conventional lathes, escomatic lathes are based on a unique concept. The material, which is coil stock or bar, does not rotate. The cutting tools mounted onto the spinning tool head rotate around the material. This concept equally qualified for the manufacturing of small, medium and large lot size parts, contributes to the extremely high performance and cost savings achieved with escomatic machines.

More flexible, more versatile, faster

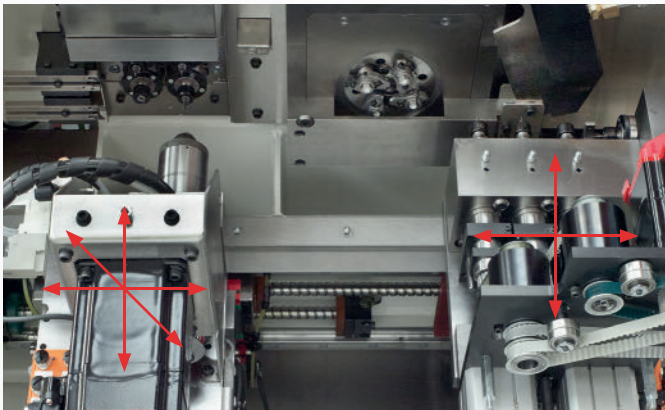

Thanks to the new design and to the use of two completely independent cross tables for the front and back machining units, the NM6 Flexi breaks the limits of flexibility and performance. Two parts can be manufactured at the same time: one part machined in the turning and front machining unit while the second part positioned in the counter spindle is undergoing back and side operations.

Technical specifications

- The escomatic technology with 4 turning tools on the rotating tool head
- Choice of escomatic cutting tools or inserts from other suppliers
- High speed manufacturing thanks to the independent front and rear machining units permitting to work on 2 parts simultaneously
- Flexibility of the straightening thanks to its' electric drive and programming from the console
- Improved quality of straightening by control over the rotating and traversing speed
- Easy access for the operator granted by the complete opening of the frontal guarding
- Easy programming by using the latest technologies of the Fanuc Oi-TF control

Very high profitability thanks to:

- Unrivaled productivity of the escomatic principle
- Very short turning times thanks to the proximity of tools
- 24 hours production facilitated by coil feeding
- No lost time due to bar loading
- Man-hour gain in material feeding
- Limited waist of material ends

TECHNICAL DATA

Turning:

Max. material diameter	6.50	mm
Work piece length standard	150	mm
Number of tools	4	
Max. toolhead speed	10'000 (12'000 option)	min ⁻¹

Front machining unit (DUF):

Number of powered tools axial	3	
Max. drilling diameter	6	mm
Max. tapping capacity	M4	
Max. drilling speed	12'000	min ⁻¹
Number of powered tools lateral (option)	1	
Max. drilling/milling speed	4'000	min ⁻¹

Back machining unit (DUA):

Max. speed of counter spindle	10'000	min ⁻¹
Number of fixed tools axial	4	
Max. drilling diameter	6	mm
Max. tapping capacity	M4	
Number of powered tools axial	4	
Number of powered tools lateral	2	
Max. drilling speed	15'000	min ⁻¹
Max. drilling diameter	5	mm
Max. tapping capacity	M3	

C-Axis:

Resolution/Increment	0.001	°
----------------------	-------	---

Numerical control:

CNC control FANUC	Oi-TF	
Max. number of controlled axes	7	
Number of spindles	3	
Measuring system resolution	0.001	mm
Rapid feed	40	m/min

Technical features:

Coolant/cutting fluid	Oil	
Tank capacity	130	Liter
Flow rate of the pump	30	l/min
Max. system pressure	8	bar
Chips container capacity	70	Liter
Installed power	8	kVA
Compressed air consumption	11	m ³ /h
Compressed air pressure	5	bar

Dimensions:

Length x Width x Height	2'270 x 1'600 x 1'700	mm
L x W x H with coil reel	3'600 x 1'650 x 1'700	mm
Net weight	1'600	kg
Gross weight	1'800	kg
Average sound pressure level	69.8	dB
Average sound power level	87.3	dB

Modifications reserved